

CUSTOMER FOCUSED • HIGHEST QUALITY PRODUCTS • ENGINEERED TO EXACT DETAIL

QUALITY VALVES

3-PC FORGED

TRUNNION MOUNTED

BALL VALVES



6" OIL MANIFOLD



12" 300 SUB SEA



FUEL GAS PACKAGE

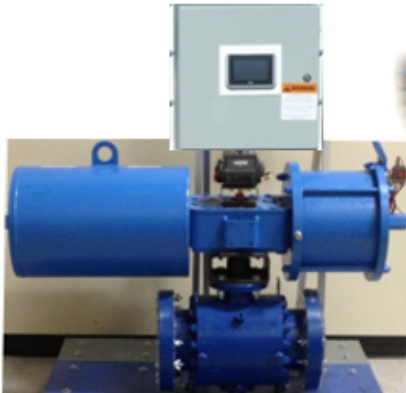

6" 600 SIL 3 HIPPS PACKAGE



16" 600 EXTENSION GAS PIPELINE



PRODUCTION 36" 600



OFFSHORE PLATFORM



PLATFORM PRODUCTION MANIFOLD



API TEST MACHINES



24" 300 CRYOGENIC -196C SERVICE



42" 600 PRODUCTION

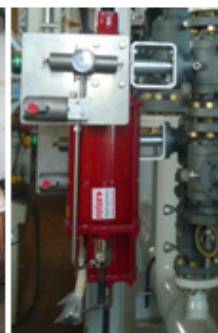

ACTUATION



FIRE SAFE TESTING



ENFLOW

Enflow is a Canadian based designer and manufacturer of high quality valves and has established a reputation as a reliable provider of technologically advanced high quality, engineered valve products for the global market. The Enflow management team has over 200 years of proven valve experience.

Valves are our core business. We are committed to Total Customer Satisfaction by meeting or exceeding our customers and industry expectations for quality and service from design to delivery.. We strive to provide a value added benefit to our customer base through design, longevity of service and technical assistance.

Enflow produces a broad range of quality valves for Oil and gas production, pipelines, utilities, shale gas and oil, processing, petrochemical, SAG-D, steam, power, waste water and mining.

Applications range from light industrial to critical areas such as cryogenic, subsea pipelines, offshore platforms, LNG, and acid gas.

ENFLOW COMPANIES

Enflow Industries Inc.	Calgary, Alberta, Canada
EF Manufacturing Inc.	Calgary, Alberta, Canada
Flow Control Oil and Gas Products division EF Manufacturing Inc.	Calgary, Alberta, Canada
Enflow Industries Equipment (Suzhou) Co. Ltd.	Suzhou, China
Enflow Hong Kong Limited	Hong Kong
Enflow FZE	Dubai, UAE

TRUNNION BALL VALVE MANUFACTURING RANGE

SIZE	ANSI 150	ANSI 300	ANSI 600	ANSI 900	ANSI 1500	ANSI 2500
1½"	•	•	•	•	•	•
2"	•	•	•	•	•	•
3"	•	•	•	•	•	•
4"	•	•	•	•	•	•
6"	•	•	•	•	•	•
8"	•	•	•	•	•	•
10"	•	•	•	•	•	•
12"	•	•	•	•	•	•
14"	•	•	•	•	•	
16"	•	•	•	•	•	
18"	•	•	•	•	•	
20"	•	•	•	•	•	
24"	•	•	•	•	•	
30"	•	•	•	•		
36"	•	•	•	•		
40"	•	•	•	•		
42"	•	•	•	•		
48"	•	•	•	•		

EVERY ENFLOW TRUNNION MOUNTED BALL VALVES IS TESTED TO API 6D, ISO 14313 AND CSA Z245.15 SPECIFICATIONS: HIGH PRESSURE HYDROSTATIC SHELL TEST, HIGH PRESSURE HYDROSTATIC SEAT TEST AND THE LOW PRESSURE AIR SEAT TEST.

MANUFACTURING STANDARDS AND QUALIFICATIONS

Enflow maintains a rigid Global Quality Management System in full accordance to ISO 9001, ISO TS 29001 (API Q1), and ABSA (Alberta/Canada Government pressure equipment safety authority) which is audited by recognized third party authorities, annually.

Our products have been third party tested to various standards including fire safe Testing: API 607 /ISO 10497, Fugitive Emission Testing: ISO 15848-1 qualification testing and ISO 15848-2 production testing, IEC 61508-2 SIL safety integrity level and Cryogenic Testing: BS 6364, our improvement to quality product verification is continuous. We have additional third party laboratory and certification programs in process. Our goal is to ensure our designs provide the optimum value for performance, safety and longevity of life.

ORGANIZATION	STANDARD	DESCRIPTION
American Petroleum Institute	API 598	Valve inspection and test
	API 6D	Specification for pipeline valves
	API 607	Fire test soft seated quarter turn valves
	API 608	Metal ball valves flanged and BW ends
	API Q1	Quality programs for petroleum & gas
American Society of Mechanical Engineers	B16.1.20.1	Pipe Threads
	B16.5	Pipe flanges and flanged fittings
	B16.10	Face to face end to end valve dimensions
	B16.25	Butt welding ends
	B16.34	Valves, flanged, threaded & welding end
	B16.47	Larger diameter steel flanges 26" to 60"
British Standards Institute	BS 6364	Valves for cryogenic service
	BS 10204	Inspection documents, metallic materials
	BS 17292	Metal ball valves - petroleum, allied industries
Canadian Standards Association	CSA B51	Boiler, Pressure Vessel & Piping
	CSA Z245.15	Steel valves for oil & gas pipeline systems
European Standardization Organizations	EN10204	Inspection Documentation for Metal parts
	EN12266-1	Seat Leakage Rates in On/Off valves
International Electromechanical Commission	IEC 61508-2	Safety of electronic systems (SIL safety integrity level)
International Organization for Standardization	ISO 5208	Pressure testing of metallic valves
	ISO 5211	Valves - part turn actuator attachment
	ISO 9001	Quality management systems
	ISO 10497	Testing of valves - fire type
	ISO 14313	Pipeline valves - Petroleum & Natural Gas Ind.
	ISO 15848-1	Fugitive emission qualification approval testing
	ISO 15848-2	Fugitive emission production testing
	ISO 21011	Valves for cryogenic service
Manufacturers Standardization Society	MSS SP-25	Standard marking systems for valves
	MSS SP-44	Steel pipeline flanges
	MSS SP-53	Quality standard valve steel castings & forgings
	MSS SP-54	Quality - valve casting & forging - radiographic
	MSS SP-55	Quality standard steel valve castings - visual
	MSS SP-72	Valves - flanged or Butt welding ends
National Association of Corrosive Engineers	NACE MR 0175	Materials for use in H2S environments
	NACE MR 0103	Materials resistant to Sulphide stress cracking in corrosive refining

ENFLOW SEATING OPTIONS

All **Enflow Trunnion Mounted Ball Valves** feature separate independent spring energized upstream and downstream seal rings to ensure absolute seal for both low pressure and high pressure conditions.

All **Enflow Trunnion Mounted Ball Valves** are available in the standard single piston effect arrangement or optional double piston effect or single x double piston effect arrangements.

Single Piston Effect

The single piston effect is commonly referred to as a safe relieving seat. Line pressure reinforces energized spring force to push both independent upstream and downstream seats against the ball for positive seal. Should cavity pressure trapped between the seats exceed the allowable limits, the excess pressure will push the seat back from the ball and automatically safely release the excess pressure to the lower pressure end of the valve. Released pressure is safely contained within the line. The valve may be installed in either direction.

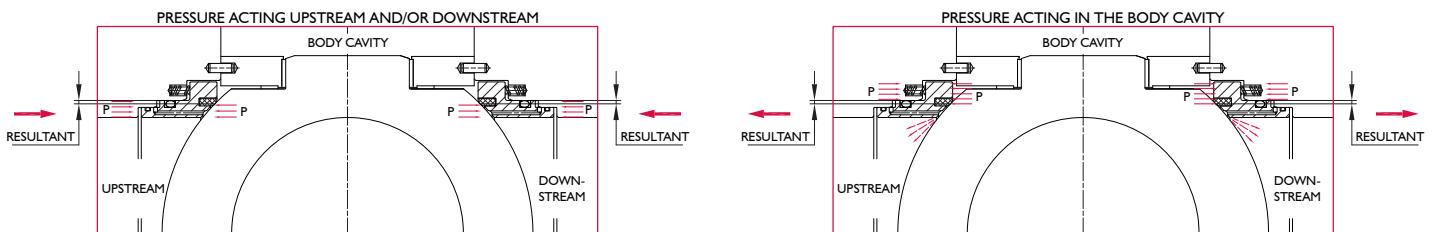

Double Piston Effect

The double piston effect design allows the higher upstream pressure in the body cavity to be utilized on the downstream side by creating an unbalanced pressure annulus between the outside diameter of the seat inset and body seal diameter. This is accomplished by allowing the body-to-seat holder seal to be forced by pressure against the body providing an increase in pressurized area on the back of the downstream seat holder. With double piston effect seating on both ends of the valve, installation orientation is not a concern. TO AVOID HAZARDOUS PRESSURE BUILD UP IN CAVITY, AN EXTERNAL VENTING RELIEF VALVE IS REQUIRED.

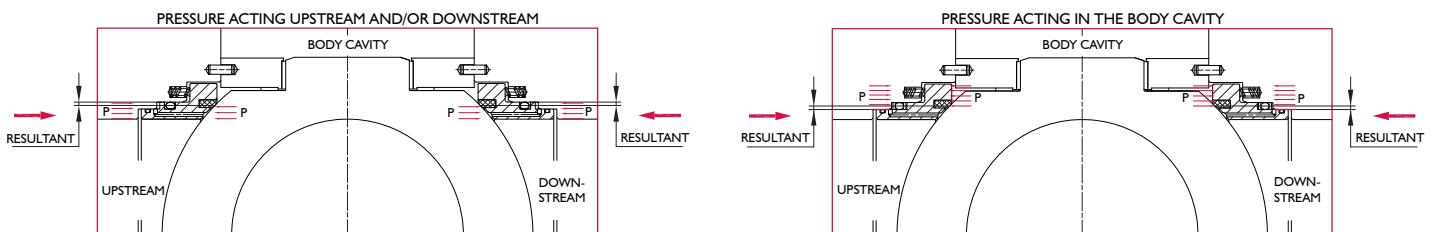

Single x Double Piston Combination

The single x double piston effect design combines the benefits of both single and double seat designs. The downstream seat utilizes the higher upstream cavity pressure to reinforce energized spring seal. The single piston seat on the upstream side automatically and safely relieves excessive levels of cavity pressure to the upstream end of valves for containment within the pipeline. This combination allows the cavity relief direction to be controlled. If the valve installation orientation is incorrect, the valve will still function as a single piston effect valve.

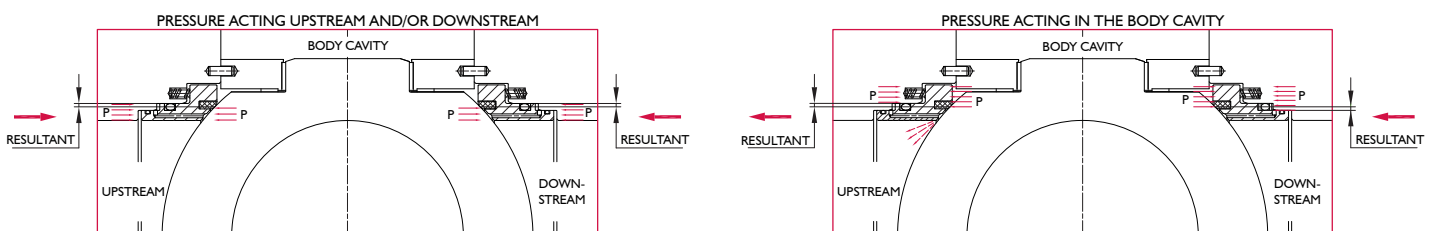

KEY FEATURES & BENEFITS

GENERAL FEATURES

- 3 piece bolted body design for ease of field service and maintenance
- Forged body, bonnet and ball material as a standard, ensures a high integrity material grain structure
- Body joint integrity is ensured by dual independent seals supported by tight toleranced overlapping metal to metal joint construction capable of withstanding pipeline stress
- Valves are double block and bleed
- Valves are antistatic tested
- Valves are fire safe tested and verified by reputable third party
- Valves have safe relieving manual bleed valve
- Valves have drain / flush plug
- All trunnion valves are equipped with a locking device. For gear operated valves, this feature is included on the gear operator
- All trunnion valves have ISO 5211 mounting flanges for ease of mounting actuators.
- Valve compliance with low emission standards
- Standard document package ISO / EN 10104.3.1

STEM DESIGN FEATURES

- Valves have anti blow out (blow out proof) stem
- Stems and trunnions are manufactured separately from the ball and supported by bearing and RPTFE thrust washer to ensure low constant torques
- Multiple independent stem packing seal systems ensures stem seal integrity
- All valves include emergency secondary stem sealant injection system

SEAT DESIGN FEATURES

- Valves have internal automatic self-relieving cavity (DPE designs are available on request)
- Special high volume seat insert design facilitate the selection of a broader range of materials while providing an increased life in difficult service conditions
- Seat ring sealing includes separate graphite seals for maximum assurance in fire conditions.
- All valves size 6” and larger (smaller sizes on special request where possible) include emergency secondary seat sealant injection system
- A separate independent check valve is beneath the seat sealant injection fittings. Our valves are hydrotested utilizing the check valve only
- Should an injection fitting be damaged, it may be replaced without the requirement of re hydrotesting the valve

OPTIONAL FEATURES

- Double piston effect seats
- Combination seats (double piston effect on one side and a self-relieving seat on the other)
- Body may be coated for corrosion protection





INDEPENDENT SEATS

Independent seats with preloaded springs ensure a bubble tight seal even at low pressures.

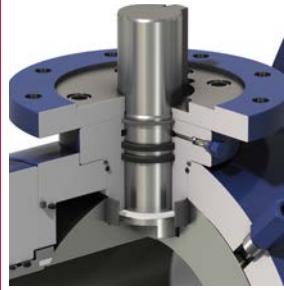

INTERNAL VALVE STOPS

The valve stops are internal, which facilitates easy correct actuation stop setting when the valve is retrofitted in the field.

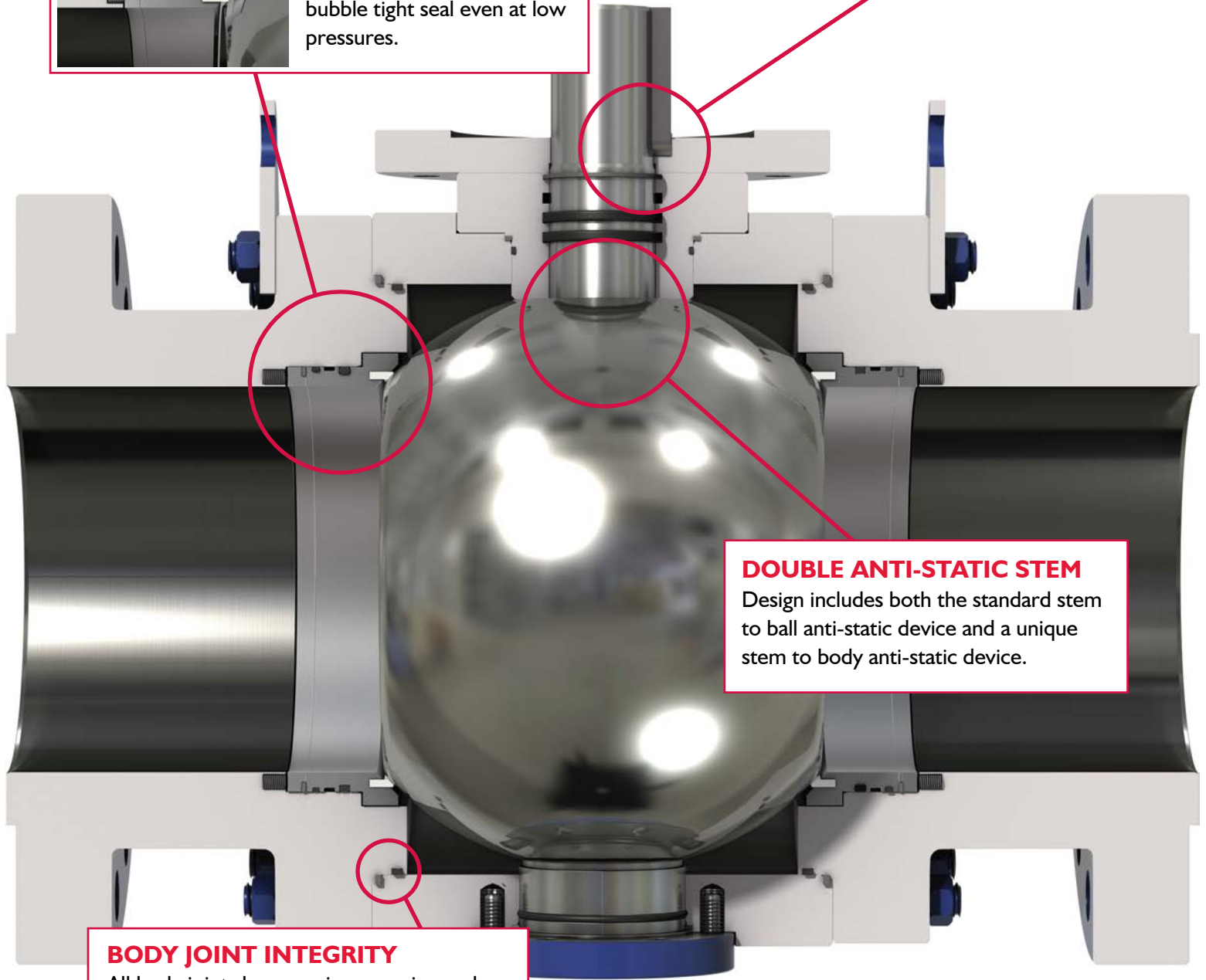

DOUBLE ANTI-STATIC STEM
 Design includes both the standard stem to ball anti-static device and a unique stem to body anti-static device.

BODY JOINT INTEGRITY
 All body joints have a primary o-ring seal backed by a secondary graphite gasket seal. This is supported by a tight tolerance metal to metal, overlapped, joint construction to ensure fire safe design conformity.

CROSS SECTIONAL DRAWING

External trunnion design, full port, lever operated

Range: 2" - 4" ANSI 150, 300 & 600
 2" - 3" ANSI 900
 2" ANSI 1500 & 2500

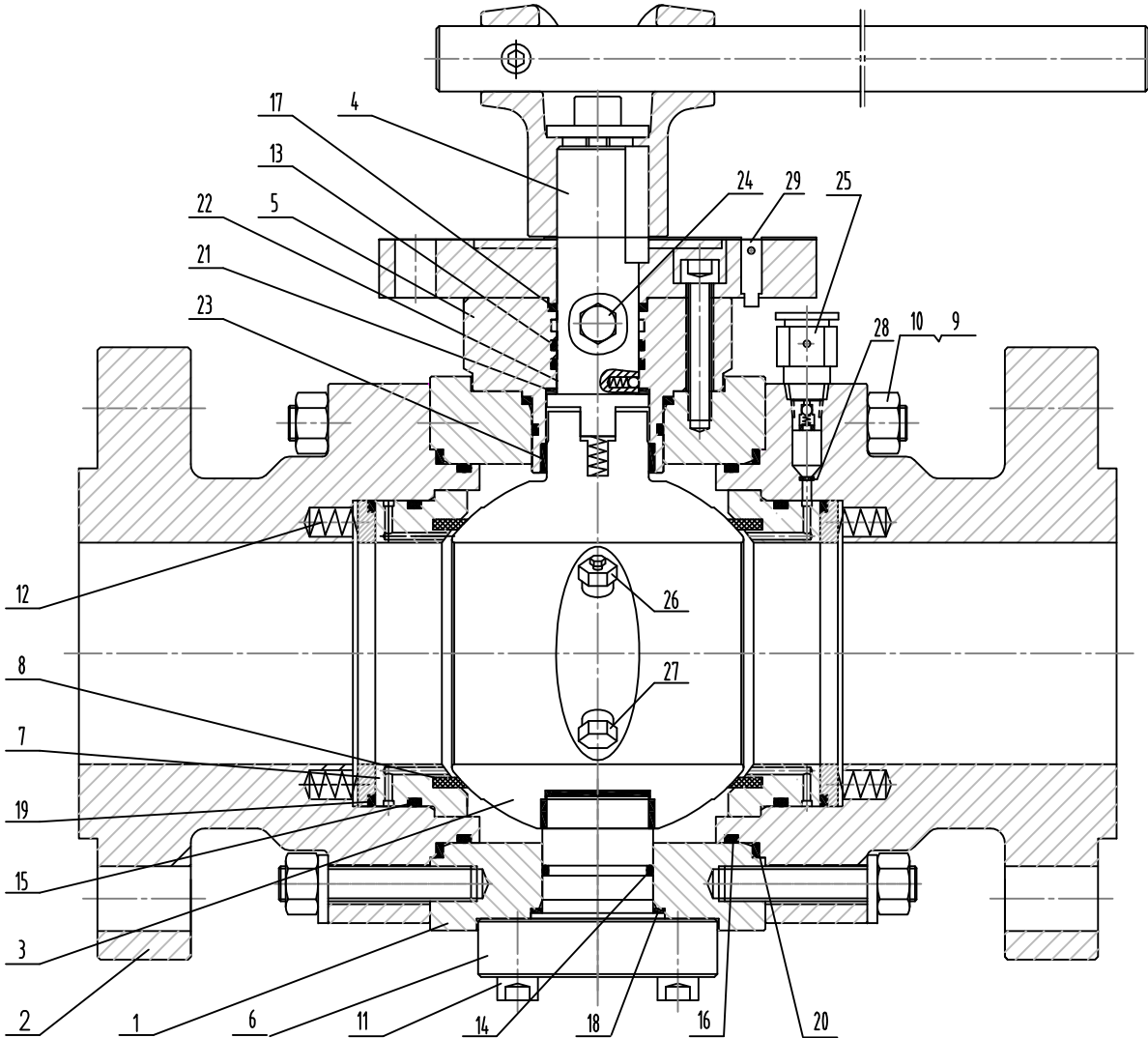

ITEM	DESCRIPTION	ITEM	DESCRIPTION	ITEM	DESCRIPTION
1	BODY	11	BOLT	21	THRUST WASHER
2	ADAPTER	12	SPRING	22	BEARING
3	BALL	13	O-RING	23	BEARING
4	STEM	14	O-RING	24	STEM INJECTION
5	BONNET	15	O-RING	25	VALVE
6	TRUNNION	16	O-RING	26	SEAT INJECTION VALVE
7	SEAT RING	17	FIRE SAFE SEAL	27	BLEED VALVE
8	SEAT	18	FIRE SAFE SEAL	28	DRAIN PLUG
9	BODY STUD	19	FIRE SAFE SEAL	29	CHECK VALVE
10	BODY NUT	20	FIRE SAFE SEAL		LOCKING DEVICE

NOTE: 2" to 4" ANSI 150 & 300 DO NOT INCLUDE SEAT SEALANT INJECTION.

The data provided in this document is subject to change without notice.

CROSS SECTIONAL DRAWING

External trunnion design, full port, gear operated

Range: 6" - 16" ANSI 150, 300 & 600

4" - 12" ANSI 900

3" & 8" ANSI 1500 & 2500

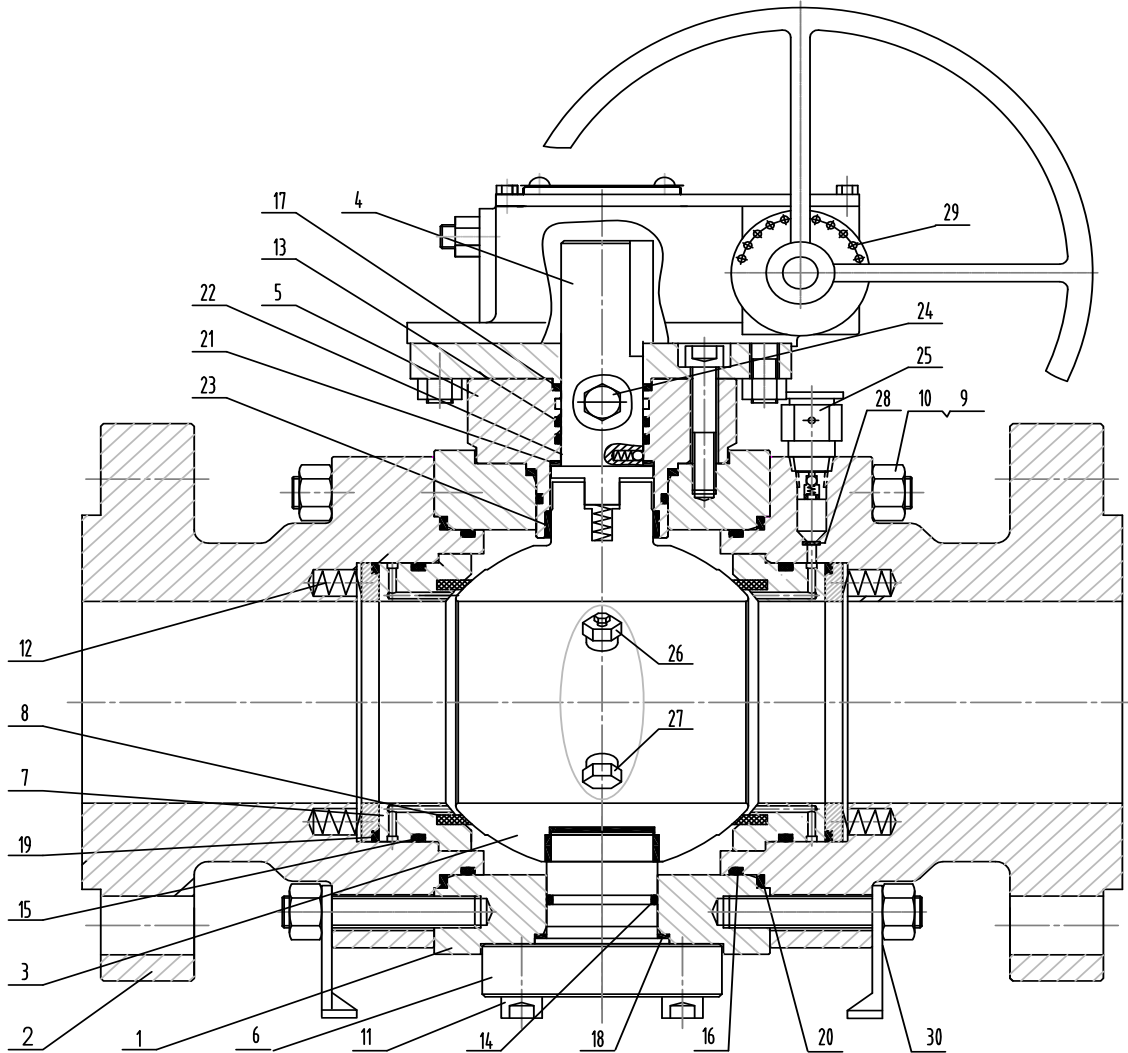

ITEM	DESCRIPTION	ITEM	DESCRIPTION	ITEM	DESCRIPTION
1	BODY	11	BOLT	21	THRUST BEARING
2	ADAPTER	12	SPRING	22	BEARING
3	BALL	13	O-RING	23	BEARING
4	STEM	14	O-RING	24	STEM INJECTION VALVE
5	BONNET	15	O-RING	25	SEAT INJECTION VALVE
6	TRUNNION	16	O-RING	26	BLEED VALVE
7	SEAT RING	17	FIRE SAFE SEAL	27	DRAIN PLUG
8	SEAT	18	FIRE SAFE SEAL	28	CHECK VALVE
9	BODY STUD	19	FIRE SAFE SEAL	29	LOCKING DEVICE
10	BODY NUT	20	FIRE SAFE SEAL	30	SUPPORT LEGS

NOTE: Support legs and lifting lugs supplied on sizes 6" and larger.

The data provided in this document is subject to change without notice.

CROSS SECTIONAL DRAWING

Internal trunnion design, full port, gear operated

Range: 18" & Larger ANSI 150, 300 & 600

14" & Larger ANSI 900

10" & Larger ANSI 1500 & 2500

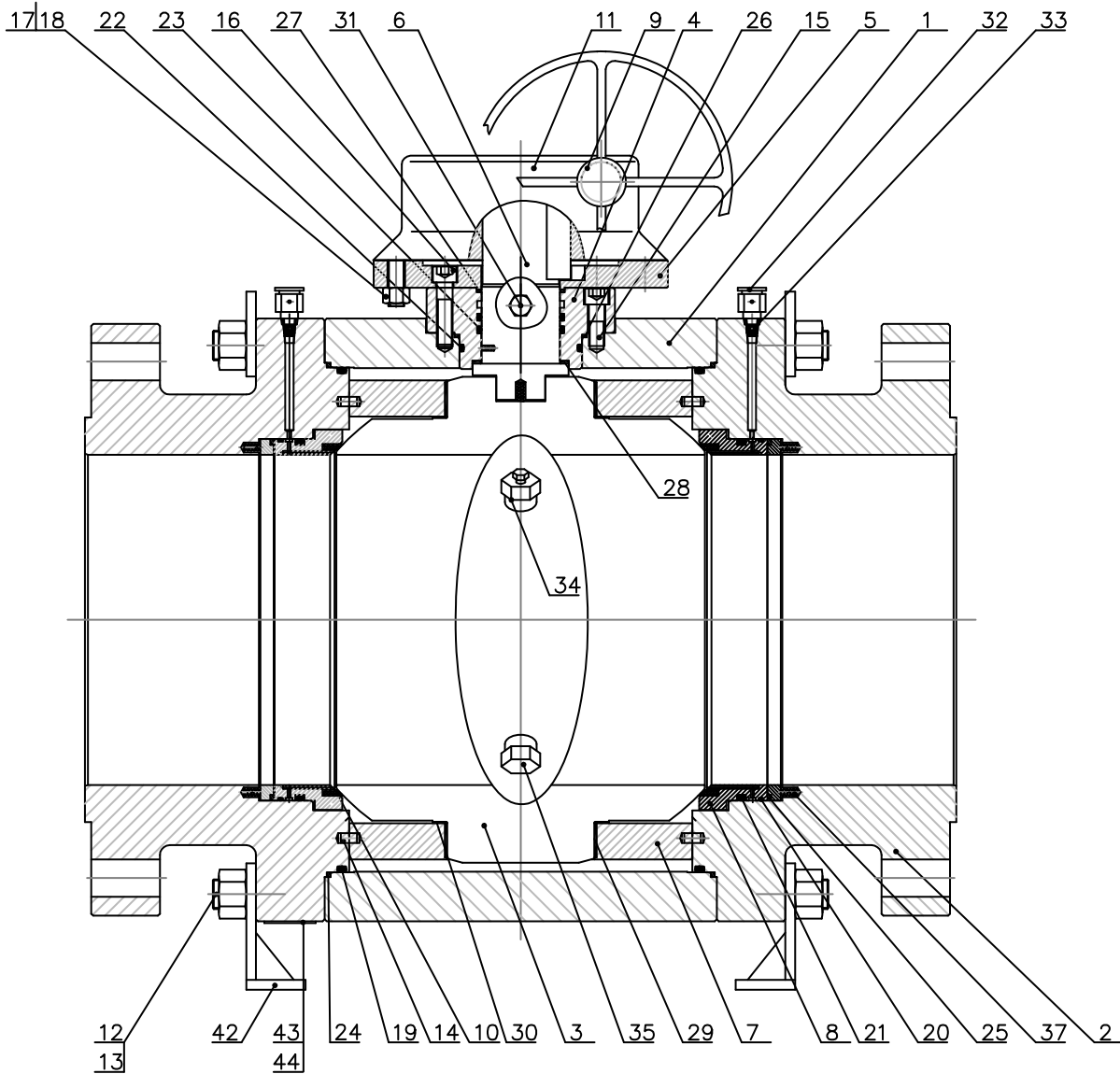

ITEM	DESCRIPTION	ITEM	DESCRIPTION	ITEM	DESCRIPTION
1	BODY	10	SEAT INSERT	24-27	FIRE SAFE SEAL
2	ADAPTER	11	GEAR	28	THRUST WASHER
3	BALL	12	BODY STUD	29	BEARING
4	BONNET	13	NUT	30	THRUST WASHER
5	BONNET FLANGE	14	BEARING BLOCK PLATE PIN	31	STEM INJECTION
6	STEAM	15,16	BOLT	32	SEAT INJECTION
7	BEARING BLOCK PLATE	17	MOUNTING STUD	33	CHECK VALVE
8	SEAT HOLDER	18	NUT	34	BLEED VALVE
9	LOCKING PLATE	19-23	O-RING	35	DRAIN PULG

NOTE: Support legs and lifting lugs supplied on sizes 6" and larger.

The data provided in this document is subject to change without notice.

SIZES & DIMENSIONS

TRUNNION 2" to 4" LEVER OPERATED

Size in inches Dimensions in mm

ANSI	SIZE	B - Port		L-RF	L-RTJ	L-WE	H	HI	LI	d
		Full	Reduced							
150	2	49	38	178	191	216	160	94	400	18
150	3	74	49	203	216	283	200	120	450	22
150	4	100	74	229	241	305	235	137	450	22
300	2	49	38	216	232	216	160	94	400	18
300	3	74	49	283	298	283	200	120	450	22
300	4	100	74	305	321	305	235	137	450	22
600	2	49	38	292	295	292	176	100	400	18
600	3	74	49	356	359	356	203	121	500	22
600	4	100	74	432	435	432	203	146	700	33
900	2	49	38	368	371	368	185	103	600	22
900	3	74	49	381	384	381	220	136	700	33
1500	2	49	38	368	371	368	185	105	600	22
2500	2	42	38	451	454	451	215	156	600	22

TRUNNION 2" to 4" GEAR OPERATED

Size in inches Dimensions in mm

ANSI	SIZE	B - Port		L-RF	L-RTJ	L-WE	H	HI	H2	A	Dia A
		Full	Reduced								
600	4	100	74	432	435	432	164	146	40	270	400
900	3	74	49	381	384	381	155	136	38.5	254	400
900	4	100	74	457	460	457	176	150	55	229	465
1500	2	49	38	368	371	368	127	105	37	254	400
1500	3	74	49	470	473	470	155	136	38.5	254	400
1500	4	100	74	546	549	546	190	168	55	229	465
2500	2	42	38	451	454	451	140	156	35	238	400
2500	3	62	42	578	584	578	173	156	40	270	400
2500	4	87	62	673	683	673	214	191	40	270	400

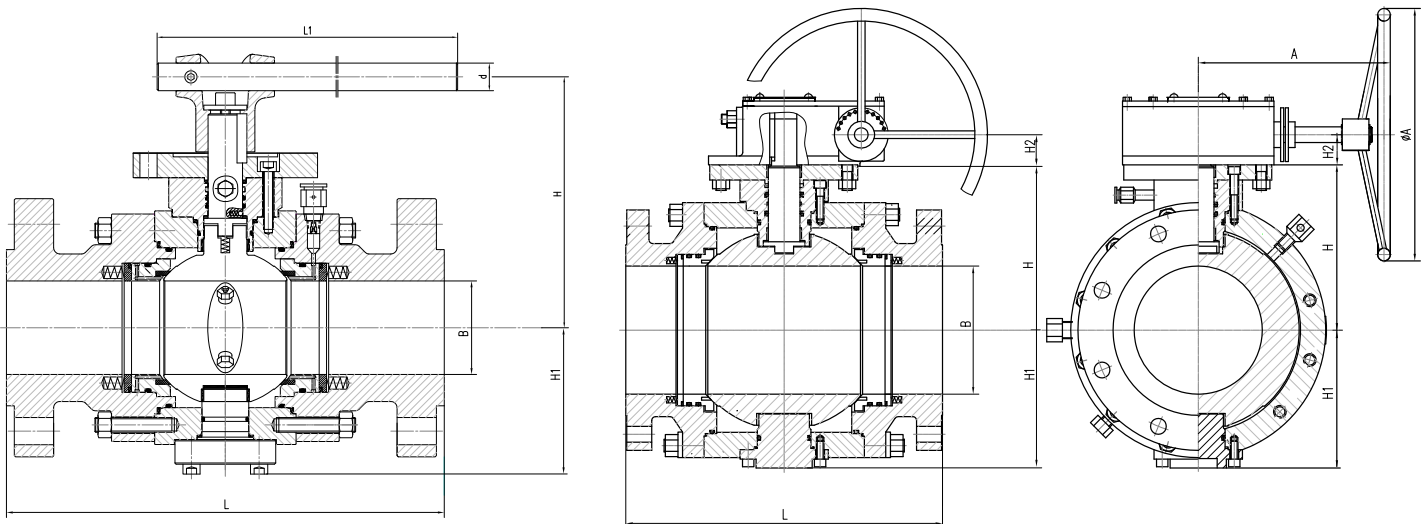

TRUNNION 6" to 48" GEAR OPERATED

Size in inches Dimensions in mm

ANSI	SIZE	B - Port		L-RF	L-RTJ	L-WE	H	HI	H2	A	dia A
		Full	Reduced								
150	6	150	100	394	406	457	227	245	55	342	400
150	8	201	150	457	470	521	252	245	55	342	400
150	10	252	201	533	546	559	295	280	55	402	600
150	12	303	252	610	622	635	323	355	55	402	600
150	14	334	252	686	699	762	363	377	55	402	600
150	16	385	303	762	775	838	410	380	55	402	600
150	18	436	334	864	876	914	449	420	77	544	750
150	20	487	385	914	927	991	486	450	77	544	750
150	24	589	487	1067	1080	1143	573	530	92.5	642	750
150	30	735	589	1295	1299	1397	694	650	92.5	642	750
150	36	874	735	1524	1528	1727	812	765	92.5	642	750
150	42	1020	874	1855	1859	2083	938	940	92.5	642	750
150	48	1166	976	2134	2138	2388	1062	1063	160	842	800

ANSI	SIZE	B - Port		L-RF	L-RTJ	L-WE	H	HI	H2	A	dia A
		Full	Reduced								
300	6	150	100	403	419	403	227	245	55	342	400
300	8	201	150	502	518	521	252	245	55	342	400
300	10	252	201	568	584	559	295	380	55	402	600
300	12	303	252	648	664	635	355	355	55	402	600
300	14	334	252	762	778	762	363	377	55	402	600
300	16	385	303	838	854	838	410	380	77	544	750
300	18	436	334	914	930	914	457	435	77	544	750
300	20	487	385	991	1010	991	510	495	92.5	642	750
300	24	589	487	1143	1165	1143	591	555	92.5	642	750
300	30	735	589	1397	1422	1397	718	675	92.5	642	750
300	36	874	735	1727	1756	1727	827	785	130	753	800
300	42	1020	874	2083	2083	2083	945	949	130	753	800
300	48	1166	976	2388	2388	2388	1084	1083	160	842	800

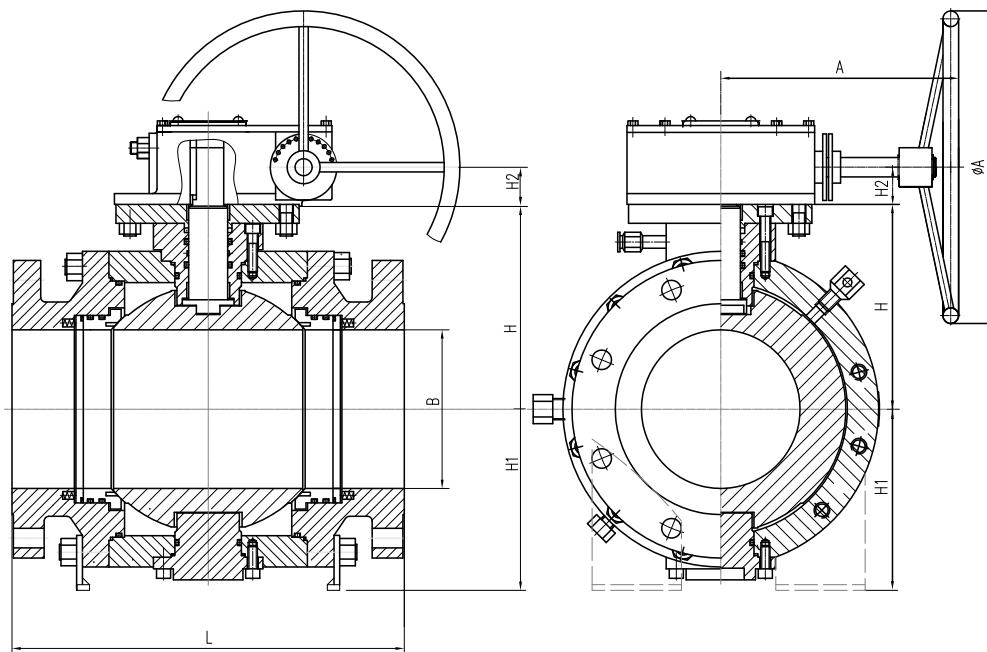

The data provided in this document is subject to change without notice.



TRUNNION 6" to 48" GEAR OPERATED

Size in inches Dimensions in mm

ANSI	SIZE	B - Port		L-RF	L-RTJ	L-WE	H	HI	H2	A	dia A
		Full	Reduced								
600	6	150	100	559	562	559	227	245	55	402	600
600	8	201	150	660	664	660	255	268	55	402	600
600	10	252	201	787	791	787	299	340	55	402	600
600	12	303	252	838	841	838	353	340	55	402	600
600	14	334	252	889	892	889	383	380	77	544	750
600	16	385	303	991	994	991	414	495	77	544	750
600	18	436	334	1092	1095	1092	475	455	77	544	750
600	20	487	385	1194	1200	1194	519	510	90	579	700
600	24	589	487	1397	1407	1397	615	585	92.5	642	750
600	30	735	589	1651	1664	1651	748	710	120	753	800
600	36	874	735	2083	2099	2083	890	845	120	753	800
600	42	1020	874	2437	2437	2437	973	977	170	842	800
600	48	1166	976	2540	2540	2540	1108	1113	170	842	800

ANSI	SIZE	B - Port		L-RF	L-RTJ	L-WE	H	HI	H2	A	dia A
		Full	Reduced								
900	6	150	100	610	613	610	232	245	55	402	600
900	8	201	150	737	740	737	277	295	55	402	600
900	10	252	201	838	841	838	320	345	77	544	750
900	12	303	252	965	968	965	384	355	77	544	750
900	14	322	252	1029	1038	1029	405	385	77	544	750
900	16	373	303	1130	1140	1130	459	470	80	545	800
900	18	423	322	1219	1232	1219	503	560	92.5	642	750
900	20	471	373	1321	1334	1321	530	656	92.5	642	750
900	24	570	471	1549	1568	1549	630	707	120	753	800
900	30	712	570	1880	1902	1880	775	789	120	753	800

ANSI	SIZE	B - Port		L-RF	L-RTJ	L-WE	H	HI	H2	A	dia A
		Full	Reduced								
1500	6	144	100	705	711	705	247	308	55	402	600
1500	8	192	144	832	841	832	333	364.5	64	380	600
1500	10	239	192	991	1000	991	351	408.5	77	544	750
1500	12	287	239	1130	1146	1130	407	482	77	544	750
1500	14	315	239	1257	1276	1257	407	481.5	92.5	642	750
1500	16	360	287	1384	1407	1384	483	522	92.5	642	750
1500	18	407	315	1537	1559	1537	595	606	120	753	800
1500	20	457	360	1664	1686	1664	680	695	120	753	800
1500	24	534	454	2043	2071	2043	758	775	120	753	800

ANSI	SIZE	B - Port		L-RF	L-RTJ	L-WE	H	HI	H2	A	dia A
		Full	Reduced								
2500	6	131	87	914	927	914	305	284	77	544	750
2500	8	179	131	1022	1038	1022	367	428.5	77	544	750
2500	10	223	179	1270	1292	1270	464	435	92.5	642	750
2500	12	265	223	1422	1445	1422	528	495	92.5	642	750

TOP WORKS DIMENSIONS

FULL PORT TRUNNION

Size in inches Dimensions in mm

ANSI 150						
SIZE	H	H2	C1	C2	C3	ISO Mounting Flange
2	107	30	18	11.5	6	F10
3	135	30	24	15	8	F10
4	171	45	32	19	10	F14
6	215	69.5	40	23	12	F16
8	258	79	45	26	14	F25
10	297	80	58	33	16	F25
12	333	80	58	33	16	F25
14	356	95	68	38	20	F25
16	405	105	72	40.5	20	F25
18	450	110	75	47	24	F25
20	485	120	98	68	28	F25
24	582	138	108	74	28	F30
30	694	143	110	75	28	F30
36	812	160	125	84	32	F35

ANSI 300						
SIZE	H	H2	C1	C2	C3	ISO Mounting Flange
2	107	30	18	11.5	6	F10
3	135	30	24	15	8	F10
4	171	45	32	19	10	F14
6	215	69.5	40	23	12	F16
8	258	79	45	26	14	F25
10	297	80	58	33	16	F25
12	333	80	58	33	16	F25
14	376.5	95	68	38	20	F25
16	409	105	72	40.5	20	F25
18	458	118	75	47	24	F25
20	502.5	123	98	68	28	F25
24	582	138	108	74	28	F30
30	720	143	110	75	28	F30
36	825	160	125	84	32	F35

ANSI 600						
SIZE	H	H2	C1	C2	C3	ISO Mounting Flange
2	121.5	30.5	24	15	8	F12
3	144	31	26	16.5	8	F12
4	175	45	34	21.5	10	F16
6	228	79	45	26	14	F25
8	275	95	58	33	16	F25
10	317	109	67	38	20	F25
12	353	109	67	38	20	F25
14	388	116	70	47	20	F25
16	429	113	85	47.5	22	F25
18	487.5	130	90	60	25	F25
20	519	130	98	69	28	F30
24	615	153	120	82	32	F35
30	750	153	120	82	32	F35
36	880	93	145	94	32	F40

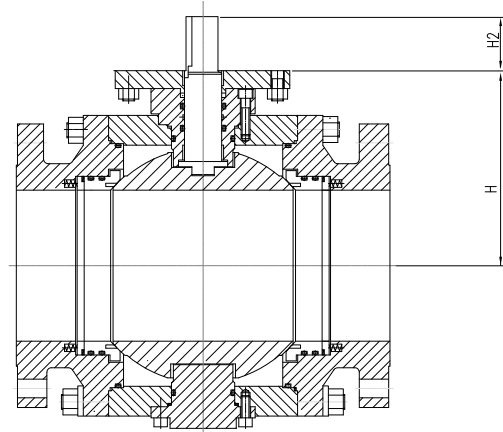
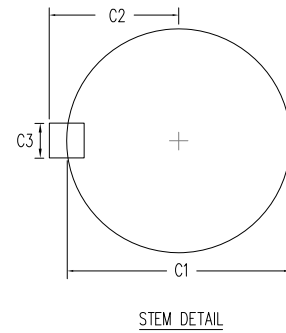

ANSI 900						
SIZE	H	H2	C1	C2	C3	ISO Mounting Flange
2	131.5	30	28	17	8	F10
3	162.5	45	36	21	10	F14
4	195	65	42	24	12	F16
6	235	79	45	26	14	F25
8	275	95	58	38	16	F25
10	326	109	67	38	20	F25
12	384	100	68	39	20	F25
16	443.5	110	85	54	24	F25
18	503	110	90	57	24	F30
20	530	138	108	69	28	F35
24	630	183	145	89	32	F40

ANSI 1500						
SIZE	H	H2	C1	C2	C3	ISO Mounting Flange
2	131.5	30	28	17	8	F12
3	170	45	36	21	10	F14
4	209	68	42	24	12	F16
6	247	95	55	36	16	F25
8	333	82	55	36	16	F25
10	351	100	68	46	24	F25
12	407	100	85	55	24	F25

ANSI 2500						
SIZE	H	H2	C1	C2	C3	ISO Mounting Flange
2	127	29	28	18	8	F12
3	155	34	38	21	10	F14
4	185	51	45	29	12	F16
6	305	82	55	36	16	F25
8	367	100	68	44	20	F25

The data provided in this document is subject to change without notice.

WEIGHTS

ENFLOW TRUNNION MOUNTED BALL VALVE WEIGHTS

Weight in Kilograms

SIZE	ANSI 150	ANSI 300	ANSI 600	ANSI 900	ANSI 1500	ANSI 2500
2	28	29	33	53	53	90
3 x 2	31	34	40	56	66	158
3	53	57	64	76	98	200
4 x 3	63	65	80	97	126	270
4	90	95	114	150	200	385
6 x 4	102	118	153	210	290	517
6	163	185	255	367	485	778
8 x 6	188	222	290	447	575	1098
8	250	287	487	600	827	1352
10 x 8	290	297	547	700	1032	1667
10	385	507	760	1027	1507	2137
12 x 10	465	597	810	1148	1767	2567
12	567	740	1070	1558	2272	3267
14 x 10	523	643	915	1235	2152	
14	765	1038	1085	1477	2880	
16 x 12	707	970	1350	1738	2807	
16	1030	1602	1527	2157	4120	
18 x 16	1080	1598	1682	2437	4980	
18	1218	1602	2097	2860	6260	
20 x 16	1170	1668	2087	2887	5150	
20	1798	2207	2640	4220	9120	
24 x 20	2048	2667	3250	5400	10950	
24	3097	3470	4740	6850	14320	
30 x 24	3347	4490	5770	8750		
28	4495	5780	6760	9970		
30	5230	6600	8380	12210		
36 x 30	6310	8190	10370	15420		
32	6820	7940	9740	11870		
36	8810	10100	13300	19920		
40	12590	13790	18340			
42	14310	16120	21360			
48	21930	24070	31200			

ENFLOW TRUNNION CV

SIZE	ANSI 150	ANSI 300	ANSI 600	ANSI 900	ANSI 1500	ANSI 2500
2	400	400	380	325	320	260
3 x 2	200	200	195	190	185	180
3	1195	1195	1100	900	830	495
4 x 3	615	615	600	595	540	540
4	2175	2175	1800	1810	1720	1110
6 x 4	850	850	800	790	780	760
6	5110	5110	4500	4300	3800	2510
8 x 6	2140	2140	2110	2100	2100	1990
8	9400	9400	9100	8600	7300	5200
10 x 8	4400	4400	4350	4300	4350	4050
10	14900	14900	14600	14550	11300	8200
12 x 10	7600	7600	7550	7550	7300	
12	23300	23300	22500	22000	17950	
14 x 10	6050	6050	6000	5950	5950	
14	27900	27900	27000	25000	20750	
16 x 12	9400	9400	9300	9000	8900	
16	37000	37000	36800	34000	27400	
18 x 16	21500	21500	21200	19500	19100	
18	49200	49200	49000	46000	36700	
20 x 16	15500	15500	15400	13850	12100	
20	60000	60000	59000	56000	48000	
24 x 20	28500	28500	28400	27100	21500	
24	91750	91750	90700	90300	69000	
30 x 24	36000	36000	36000	32400		
28	120000	120000	120000	112000		
30	145000	145000	144000	129000		
36 x 30	64000	64000	63100	61000		
32	17000	17000	168000	150000		
36	21100	21100	210000	197700		
40	26800	26800	267000			
42	28000	28000	278000			
48	38500	38500	384000			

BODY AND TRIM MATERIALS

CARBON STEEL	A105N, A 216 WCB
LOW TEMPERATURE CARBON STEEL	A350 LF2 class I, A352 LCC
LOW ALLOY STEEL	ANSI 4140, A29 4140, A350 LF3
MARTENSITIC STAINLESS STEEL	AISI 410, A182 6A, A217 CA15, A182 F6NM, A487 CA6NM
AUSTENITIC STAINLESS STEEL	A182 F316, A182 F316L, NITRONIC 50 (A182 XM-19 / UNS S20910), A351 CF8M, A351 CF8, A351 CF3M
PRECIPITATION HARDENING STAINLESS STEEL	17-4PH (A564 GR 630 H1150M, UNS S17400)
DUPLEX STAINLESS STEELS	A182 F51 (UNS S31803), A890 4A (UNS S31803), A182 F55 (UNS S31760), A890 6A (UNS S32760)
NICKEL ALLOYS	INCONEL 625 (UNS N06625), INCOLOY 825 (UNS N08825), MONEL 400, MONEL K500
OTHER	UPON REQUEST

SEAT AND SEAL MATERIALS PRESSURE TEMPERATURE LIMITS AND ANSI CLASS APPLICATION

GENERAL MATERIAL PROPERTIES AND ANSI CLASS APPLICATIONS (refer to following reference chart for pressure / temperature limits)			
MATERIAL	TEMPERATURE CELSIUS		ANSI CLASS STANDARD OFFERING
	MINIMUM	MAXIMUM	
DEVLON (NYLON 6 PLUS)	-60	149	ANSI 600 TO ANSI 1500
MOLON (NYLON 6 PLUS)	-60	149	
NYLON 12G	-40	120	
PCTFE	-196	150	ANSI 150 TO ANSI 2500 (CRYOGENIC SERVICE)
PEEK	-60	300	ANSI 2500 (LOWER ANSI ON REQUEST)
RPTFE (25% GLASS FILLED)	-100	230	ANSI 150 TO ANSI 300 (ANSI 600 TO 4" ON REQUEST)
RPTFE (15% GLASS OR CARBON FILLED)	-100	220	ANSI 150 TO ANSI 300
HNBR	-40	149	ALL ANSI CLASSES
FKM B (VITON B)	-29	204	
PTFE + ELGILOY SPRINGS (LIP SEAL)	-196	200	ALL ANSI CLASSES (CRYOGENIC SERVICE)

REFERENCE PRESSURE/TEMPERATURE CHART

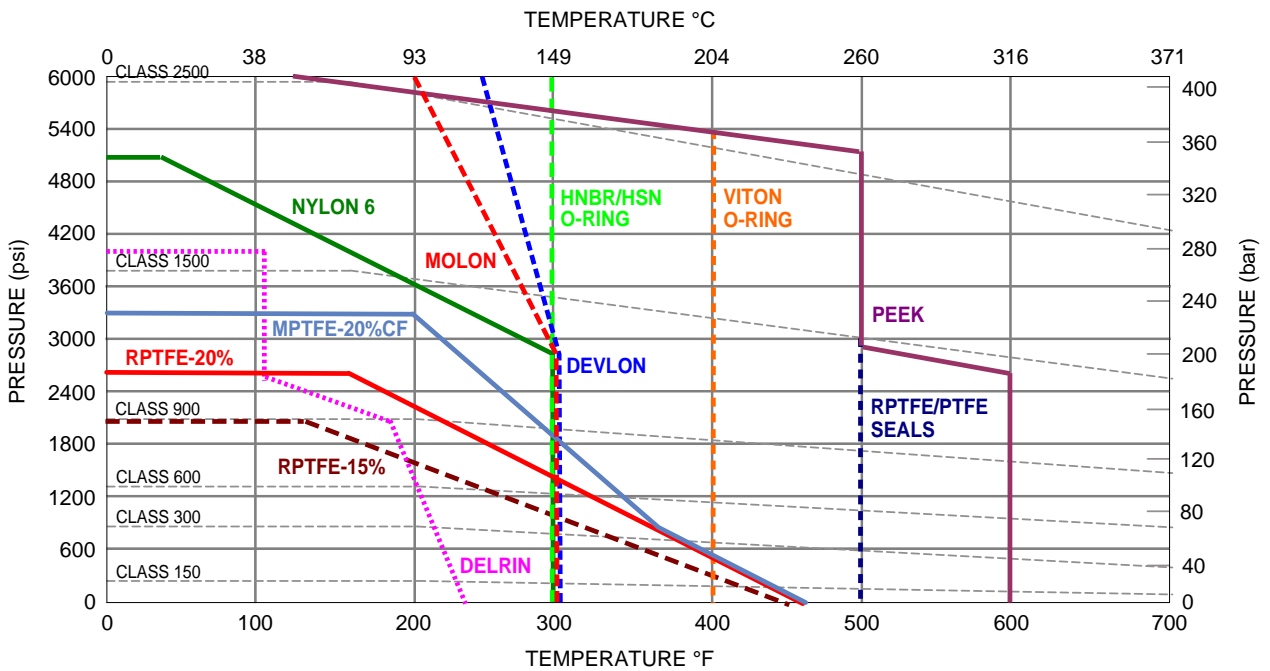

Consult ASME 16.34 for specific material pressure/temperature ratings.
Consult Meridian for specific information.

July 19th, 2012

Consult Enflow Industries Inc. Engineering for Specific Information

ENFLOW TRUNNION MOUNTED BALL VALVE BREAK TORQUES

Break torques may vary depending on seat material, temperature and service conditions. We recommend an additional safety factor of 35% be applied to the following for actuation.

All torques are in NM

SIZE (inches)	ANSI 150	ANSI 300	ANSI 600	ANSI 900	ANSI 1500	ANSI 2500
2	57	60	160	180	320	599
3	80	180	330	512	750	1400
4	155	290	495	861	1238	2900
6	420	710	1300	1575	3231	5854
8	800	1390	2180	3800	5950	9290
10	1100	2280	3050	5270	8731	13200
12	1500	2550	3825	7950	13550	18150
14	1946	3710	6520	9975	18550	
16	3050	5139	8900	13825	25500	
18	3893	7085	13347	20400		
20	4973	10925	17015	25996		
24	8328	14958	24900	45372		



RECOMMENDED SPARE PARTS

Spare parts are sold in kits. Each kit contains 2 (two) SEAT ASSEMBLIES and all SOFT PARTS. For valves in service, please advise SERIAL NUMBERS as designs are subject to revisions.

RECOMMENDED PARTS KITS: (for identical valves)	START UP COMMISSIONING	2 YEAR OPERATION
	1 KIT per 10 VALVES	1 KIT per 25 VALVES



ENFLOW BALL VALVE FIGURE NUMBERING SYSTEM

1 TYPE	2 SIZE	3 PORT	4 PRESSURE	5 BODY DESIGN	6 ENDS	7 BODY MATERIAL	8 TRIM MATERIAL		9 SEATS / SEALS		10 OPERATOR
EB	02	R	01	2T	A	01	E1	S5	B	P	L
	03		F	03	3T	B	02	E3	S6	C	T
	04		06	4T	F	03	E7	S7	E	V	G
	06		09	5T	G	04	S1	S8	F	X	O
	08		15		H	05	S2	S9	M	O	
	10		25		J	08	S3	10	N		
	12				X	OO	S4	OO			
	thru				O						
	48										

1	TYPE	EB = ENFLOW BALL VALVE									
2	SIZE	02 = 2" 03 = 3" up to 48"									
3	PORT	R = REDUCED F = FULL									
4	PRESSURE	01 = ANSI CLASS 150 03 = ANSI CLASS 300 06 = ANSI CLASS 600					09 = ANSI CLASS 900 15 = ANSI CLASS 1500 25 = ANSI CLASS 2500				
5	BODY DESIGN	2T = 2 PIECE BOLTED BODY 3T = 3 PIECE BOLTED BODY					4T = TOP ENTRY 5T = WELDED BODY				
6	ENDS	A = RAISED FACE FLANGED B = RTJ FLANGED F = BUTT WELD ENDS G = BUTT WELD END x RAISED FACE FLANGED END					H = BUTT WELD END x RTJ FLANGED END J = WELD ENDS WITH PUPS X = HUB ENDS O = OTHER				
7	BODY MATERIAL	01 = WCB / A105N 02 = LCC / LF2 CLASS I 03 = CF8M / F316 04 = 22CR DUPLEX / F51					05 = 25CR DUPLEX / F55 08 = INCONEL 625 OO = OTHER				
8	TRIM	E1 = BODY MATERIAL + 1 MIL ENP E3 = BODY MATERIAL + 3 MIL ENP E7 = BODY MATERIAL + 3 MIL ENP, 4140 STEM + 3 MIL ENP S1 = 316Lss S2 = 304ss / F304 S3 = 316ss / F316 S4 = 410ss / F6A S5 = 22CR DUPLEX / F51 S6 = 25CR DUPLEX / F55 S7 = 316ss TRIM, 17-4PH STEM S8 = 316ss TRIM, NITRONIC 50 STEM S9 = 17-4PH STEM, F51 BALL & SEAT HOLDER, 316ss TRUNNION & SEAT FOLLOWER 10 = 17-4PH + 1 MIL ENP TRIM OO = OTHER									
9	SEATS / SEALS	B = RPTFE SEAT / HNBR SEALS, GRAPHITE FIRE SAFE SEALS C = NYLON SEAT/ HNBR SEALS, GRAPHITE FIRE SAFE SEALS E = PEEK SEAT / HNBR SEALS, GRAPHITE FIRE SAFE SEALS F = DEVLON, MOLON SEATS / HNBR SEALS, GRPHITE FIRE SAFE SEALS M = METAL to METAL SEATING / SEALS TO BE DETERMINED ON APPLICATION N = NYLON SEATS / VITON B SEALS, GRAPHITE FIRE SAFE SEALS P = PEEK SEATS / VITON B SEALS, GRAPHITE FIRE SAFE SEALS T = RPTFE SEATS /VITON B SEALS, GRAPHITE FIRE SAFE SEALS V = DEVLON, MOLON SEATS / VITON B SEALS, GRAPHITE FIRE SAFE SEALS X = PCTFE SEATS / PTFE SEALS, GRAPHITE FIRE SAFE SEALS O = OTHER									
10	OPERATOR	L = LEVER B = BARE STEM					G = GEAR O = OTHER				

A SELECTION OF ENFLOW CUSTOMERS AND USERS

AGIP	LIBYA	ESSO PRODUCTION MALAYSIA	MALAYSIA
ADDAX PETROLEUM	OFF SHORE NIGERIA	EXXON MOBIL KEARL LAKE	CANADA
AI FURAT PETROLEUM	SYRIA	EXXON MOBIL	OFFSHORE NEW GUINEA
ALTA GAS	CANADA	EXXON MOBIL	OFFSHORE AFRICA
AMARADA HESS	USA	FERTIMEX	MEXICO
ANADARKO	USA	FLAREON SYSTEMS	MALAYSIA
APACHE	CANADA	FLOW SYSTEMS	MALAYSIA
ARCO (BP)	USA	FRASER UNICAL	MALAYSIA
ARCO (BP)	INDONESIA	FRED OLSEN PRODUCTION	OFFSHORE NIGERIA
ASAMERA	INDONESIA	GAS LIQUIDS ENGINEERING	CANADA
BMW WEATHERFORD	CANADA	GAS MALAYSIA	MALAYSIA
BP	INDONESIA	GLACIER RIDGE RESOURCES	CANADA
BP	INDIA	GLOBAL PROCESS SYSTEMS	MALAYSIA, UAE
BURLINGTON RESOURCES	CANADA	GRIZZLY OIL SANDS	CANADA
BWS	CANADA	HALIBURTON ENERGY SERVICES	INDONESIA
BONATI SPA	ITALY	HESS CORP	USA
BOW RIVER PIPELINES	CANADA	HSP /MCCULLOUGH	UK
BROWN AND ROOT	USA	HUSKY - VARIOUS	CANADA
BOPP & REUTHER	GERMANY	HUSKY - TANK FARMS	CANADA
CANADIAN HUNTER EXPLORATION	CANADA	HUSKY HEAVY OIL (VARIOUS)	CANADA
CANADIAN NATURAL RESOURCES	CANADA	HYUNDAI HEAVY INDUSTRIES	KOREA
CANADIA OCCIDENTAL PETROLEUM	YEMEN	IMV PROJECTS	CANADA
CANADIAN NEXEN PETROLEUM	YEMEN	KAVERNER PROCESS	CANADA, NORWAY
CANADIAN NEXEN PETROLEUM	CANADA	KEYERA	CANADA
CENTRA GAS	CANADA	KOCKEN ENERGIA	MEXICO
CERGILL	USA	KUWAIT NATIONAL PETROLEUM	KUWAIT
CHINA NATIONAL PETROLEUM CO (CNPC)	CHINA	MALAYSIA LNG	MALAYSIA
CLIPPER ENERGY	EQUADOR	MASOURA PETROLEUM COMPANY	EGYPT
COOGEE RESOURCES	OFFSHORE AUSTRALIA	MAXUS	EQUADOR
CRESSENT PETROLEUM	IRAQ	MCJUNKIN REDMAN	USA
CUU LONG JOINT OP CO (CLJOC)	VIETNAM	MEG ENERGY	CANADA
CZAR RESOURCES	CANADA	MERCADOR	SINGAPORE
DEVON JACKFISH	CANADA	MOTO MECHANICA	ARGENTINA
ELAN ENERGY	CANADA	MURPHY OIL	CANADA
EMCO	CANADA	MURPHY SARAWAK OIL	MALAYSIA
ENCANA CABIN PROJECT	CANADA	MUSTANG ENGINEERING	USA
ENCANA PELICAN LAKE	CANADA	NATCO	CANADA
ENCANA (various)	CANADA	NATIONAL IRANIAN GAS COMPANY	IRAN
ENERFLEX	CANADA	NATIONAL IRANIAN OIL COMPANY	IRAN
ESSO BALDER	NORWAY	NEPOMUCENO	COLUMBIA

NEXEN LONG LAKE	CANADA
NORTH OIL COMPANY (NOC)	IRAQ
NNPC	NIGERIA
OCCIDENTAL OF OMAN INC	OMAN
OMV	NEW ZEALAND
PACIFIC NORTHERN GAS	CANADA
PEMEX	MEXICO
PENN WEST PETROLEUM	CANADA
PETRECO	CANADA
PETRECO SARL	BULGARIA
PETROBRAS	BRAZIL
PETRO INDUSTRIAL	EQUADOR
PETROCON	UK
PETROFAC MALAYSIA	MALAYSIA
PETROINRAN	IRAN
PETRONAS	MALAYSIA
PETRONAS CARIGALI	MALAYSIA
PETROVIETNAM	VIETNAM
PLAINS FABRICATION DIV PLAINS OIL	CANADA
POCO PETROLEUM	CANADA
PREMIER PETROLEUM	MYANAMAR
PROPAK SYSTEMS	CANADA
PTT	THAILAND
QATAR PETROLEUM DEVELOPMENT	QUATAR
REPSOL	LIBYA
ROMPETRO OF LIBYA	LIBYA
SAIPEM	UAE, ITALY, CANADA
SANTOS	INDONESIA
SASKENERGY	CANADA

SINGLE BOUY MOURINGS (SBM)	MALAYSIA, SINGAPORE
SINGLE BOUY MOURINGS (SBM)	MALAYSIA, SINGAPORE
SHELL SARAWAK	MALAYSIA
SHELL BRUNAI	BRUNAI
SHELL IRAN	IRAN
SHERRITT	CANADA
SK ENGINEERING	KOREA
SNAMPROGETTI CANADA	CANADA
SOUTH OIL COMPANY (SOC)	IRAQ
SUNCOR ENERGY	CANADA
SYNERGI	CANADA
SYRIA PETROLEUM COMPANY (SPC)	SYRIA
TALISMAN MALAYSIA	MALAYSIA
TANJUNG OFFSHORE	MALAYSIA
TANKER PACIFIC OFFSHORETERMINALS	SINAPORE, VIETNAM
TECHNICS OFFSHORE	SINGAPORE
TECKNICA	UK
THUMBS	USA
TODD ENERGY	CANADA
TOTAL ARGENTINA	ARGENTINA
TOTAL YEMEN	YEMEN
ULTRAFAB	CANADA
UNOCAL	INDONESIA, THAILAND
VICO	INDONESIA
VIETSOVPETRO	VIETNAM
WEATHERFORD UAE	UAE, TURKEY, IRAQ
WESTERN GAS PROCESSORS	USA
YPFB	BOLIVIA
ZUTINA OIL COMPANY	LIBYA





CUSTOMER FOCUSED • HIGHEST QUALITY PRODUCTS • ENGINEERED TO EXACT DETAIL • UNCOMPROMISING SAFETY STANDARDS

Enflow

INDUSTRIES INC.

Head Office:

3740 E - 11A Street NE

Calgary, Alberta, Canada T2E 6M6.

Telephone (403) 266-4977 Facsimile (403) 266-7334

www.enflow.ca
sales@enflow.ca